



3561 Truman Road OFFICE, Perrysburg, OH 43551
Phone (419) 837-6929 Fax (419)-837-9925

Design Approval Form Instructions

BEFORE starting or purchasing material for your project you must request permission to make any exterior alteration to the home or homesite as provided in the Community Covenants. You must complete a design approval form with all sizes including height, width and depth of the intended project if applicable. In addition, you must submit your type of material, color swatch for any painting, and spec sheets of any complex materials being used.

Once received, management will review the plan and do an onsite inspection. During this pre-construction inspection we will determine if the proposed plan does not interfere with underground utilities, lot lines or any additional issue that may arise due to lot condition or layout. Please allow 10-20 business days for this review and approval. Once a decision has been made on the project we will notify you in writing of the decision. Any design approval forms received without the above-listed information or not in compliance with the Community Covenants will be rejected.

If you plan to use a subcontractor for your project, you must provide a copy of their certificate of liability insurance with the submission of the design form. If you plan to do the work yourself, you must provide a copy of your home owners insurance. If your project consists of a deck, deck railing or steps, the project must follow the "Wooden deck Specifications" attached hereto.

Once the approval has been given you will have (30) days to complete the project unless otherwise specified and agreed to by Management.

Thank you!

-Management

WOODEN DECK SPECIFICATIONS

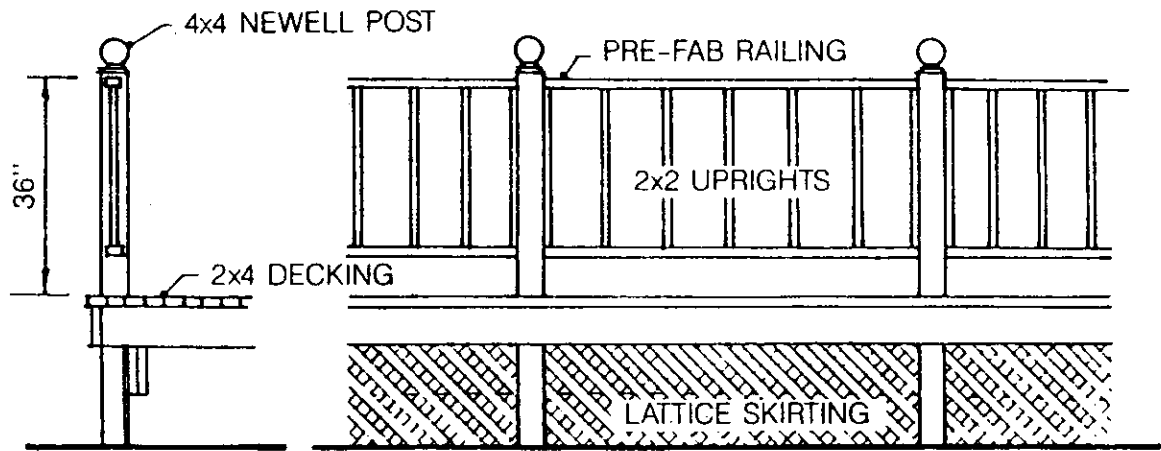

PRE-FAB POST & RAILING

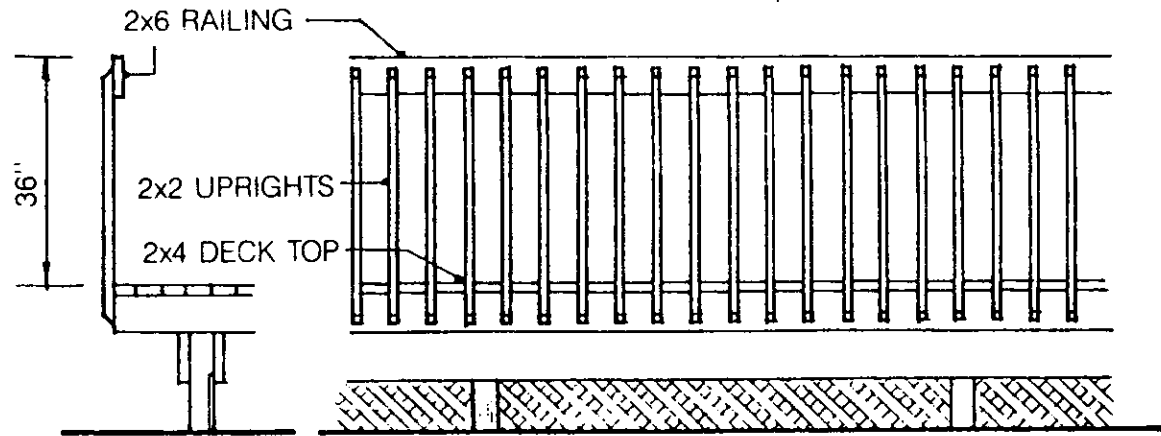

2x6 RAILING WITH 2x2 UPRIGHTS

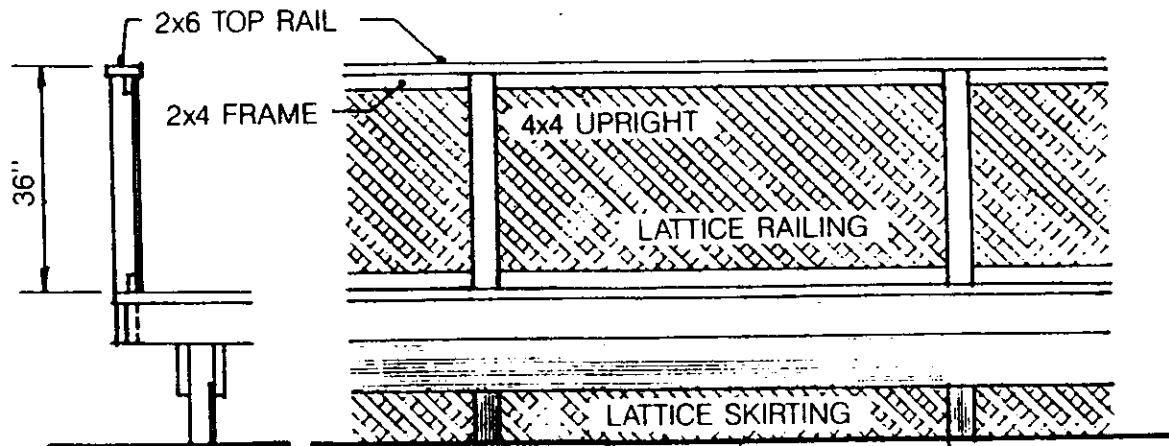

LATTICE RAILING WITH 4x4 UPRIGHTS

TYPICAL STAIR DETAIL

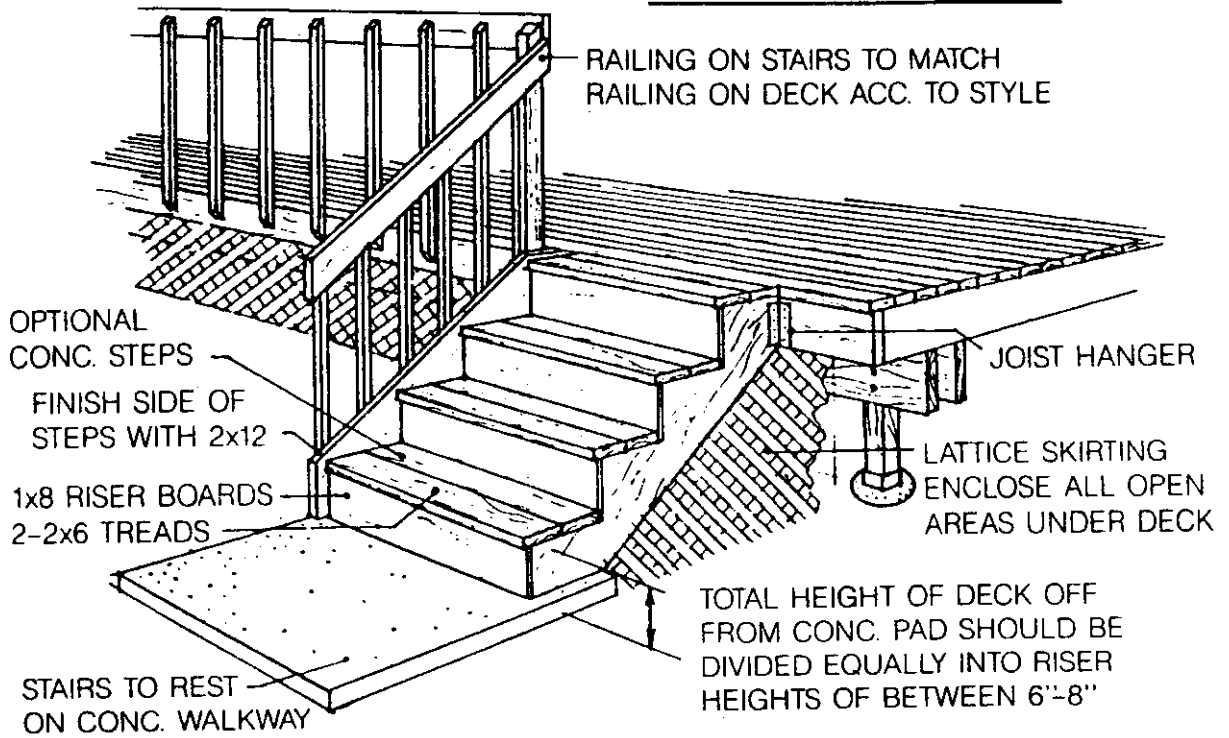

FULL BENCH WITH
BACKREST ATTACHED
TO RAILING

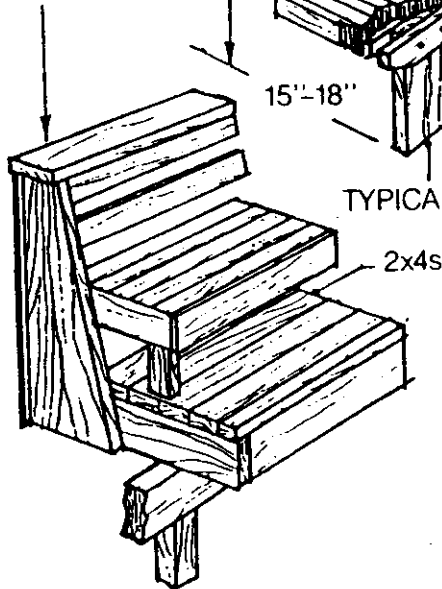

BENCH DETAILS

FREE-STANDING BENCH
2x2 WITH 2x4 BORDER

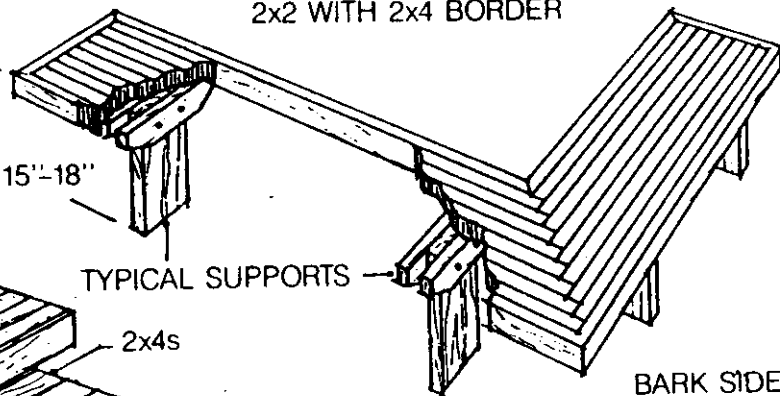

ALL DECKING BOARDS
SHOULD BE NAILED WITH BARK SIDE UP
TO HELP PREVENT CHECKING, SPLITTING, AND
CUPPING OF BOARDS. THE BARK SIDE OF THE
BOARD CAN BE DETERMINED BY LOOKING AT
THE END GRAIN OF THE BOARD AND FACING
THE RINGS OF THE GRAIN DOWNWARDS.

CROSS SECTION - CONSTRUCTION DETAILS

SCALE: 1"=1'-0"

